

The solution to strategic problems in the oil refining industry as a factor for the sustainable development of automobile transport

E. Magaril

*Department of Environmental Economics,
Ural Federal University, Russia*

Abstract

The oil refining industry in Russia produces poor quality motor fuels that meet neither the standards of developed countries nor the needs of a rapidly growing domestic vehicle fleet. The aim of this work is to substantiate the optimal direction for reforms to modernize the Russian oil industry, which will then enable it to achieve in a timely manner the necessary changes to the quality of motor fuel that will improve both the energy efficiency and environmental safety of motor vehicles. The prospective requirements for fuel quality in Russia were formulated based on analytical investigation. The necessity to change the ratio between reforming and isomerization capacities to improve fuel properties is herein demonstrated. The proposed scheme for highly efficient residueless oil refining will give a motor fuel yield of approximately 85% with inherent high environmental and operational characteristics. The optimal direction for the rapid improvement of the quality of motor fuels through the use of the developed multifunctional fuel additive in trace amounts is proposed.

Keywords: fuel quality, isomerization capacity, residueless oil refining, multifunctional additive.

1 Introduction

Fuel quality is the most important factor in determining the efficiency and environmental safety of the operation of vehicles. The Russian vehicle fleet has grown rapidly in recent decades but the fuel quality has not significantly



improved. Levels of toxic emissions from Russian vehicles are far behind the modern standards of developed countries. This is determined by several factors. On the one hand, up until now the domestic automotive industry has produced vehicles that do not meet modern European standards on emissions from motor vehicles. On the other hand, oil-refining plants do not have the capability of producing motor fuels of a high quality. Also, the production of adulterated motor fuel, to a greater or lesser extent, reaches 30% in Russia and that along with the lack of control on the gasoline stations further exacerbates the problem of attaining the desired fuel quality. Fundamental improvement to the vehicle fleet with the priorities of environmental safety, energy efficiency and its sustainable development requires a rapid improvement in the quality of motor fuels used.

2 The influence of fuel quality on the operational and environmental characteristics of vehicles

2.1 Theoretical study of the influence of the fuel's chemical composition on the characteristics of vehicles

Theoretical analysis done by the author on the composition of exhaust gases using chemical thermodynamics shows that the concentrations of carbon and nitrogen oxides in exhaust gases are much higher than ones of equilibrium and they are determined by the peak flame temperature [1–3]. According to the author's calculations, at a stoichiometric air-fuel ratio, the peak temperature increases with increased fuel unsaturation and reaches the maximum for aromatic hydrocarbons (fig. 1). In the stoichiometric air – C_nH_{2n-x} fuel mixture, an increase in x leads to an increase in the heat generated per cycle while reducing the combustion heat (table 1).

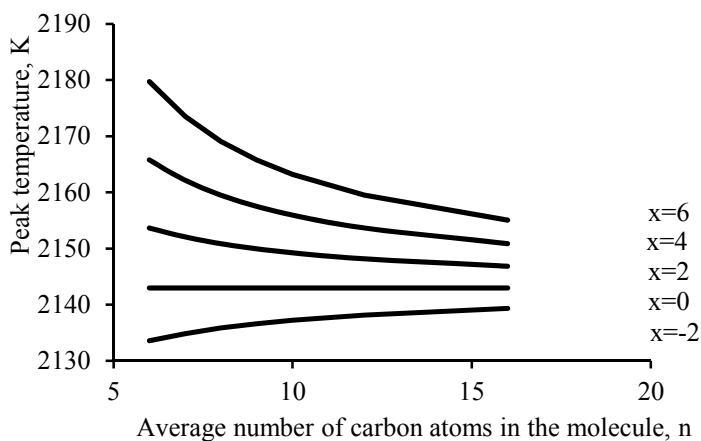

Figure 1: The dependence of the peak temperature at adiabatic combustion of the stoichiometric hydrocarbon fuel-air mixtures on the elemental composition of C_nH_{2n-x} fuel.

Table 1: Influence of the elemental fuel composition on the relative efficiency (heat release) and calorific efficiency at the combustion of the stoichiometric hydrocarbon fuel-air mixture at 700 K.

Hydrocarbon fuel	Relative values, %	
	Heat release per cycle	Heat of combustion
2- methylpentane	99.6	100.9
2,2,4-trimethylpentane	100.0	100.0
decane	100.7	100.0
benzene	102.4	90.8
ethylbenzene	102.1	92.6
butylbenzene	101.5	93.3

Aromatic hydrocarbons give a slight increase in engine power, but fuel consumption is considerably higher. It should be noted that an increase in the gasoline aromatization reduces its consumption per litre with its relevant increasing per kilogram and since the calorific fuel efficiency Q , measured in kJ/kg, is lower for aromatic hydrocarbons, the Q value measured in kJ/l ($Q \text{ kJ/kg} \cdot \rho \text{ kg/l} = Q \text{ kJ/l}$) for the aromatic hydrocarbons will be higher than for the aliphatic ones.

Throughout Russia gasoline is sold in weight units, except for gas stations. The direct selling of gasoline to the consumer in volume units stimulates the consumption of a highly aromatized gasoline. To accustom consumers to more environmentally friendly motor fuels it is necessary to sell them in kilograms rather than litres.

Our calculations based on thermo chemical data indicate that the production of CO_2 increases linearly with the density of the fuel, and the density, as it is known, increases with an increase in aromatic hydrocarbon fuel content. Furthermore, due to the low oxidation rate of aromatic hydrocarbons, their increased content leads to an increase in the emission of hydrocarbons and products of their incomplete oxidation within the exhaust gases. The concentration of benzene in the exhaust gas hydrocarbons is at least three times greater than that in the initial gasoline. The reactions of thermal condensation within the wall's boundary film lead to the formation of the highly carcinogenic substance – benzo(a)pyrene from the aromatic hydrocarbons. An increase in the degree of fuel aromatization in diesel engines increases the formation and subsequent emission of soot within the exhaust gases.

Up to 2% of gasoline evaporates during its storage, transportation, loading and from the fuel system of vehicles. Our calculations on the toxicity of the gasoline vapour from the standard Russian fuel AI-93 (with research octane number (RON) 93) [1, 2] have shown that approximately 50% of the total toxicity is caused by benzene. It should be noted that under normal conditions benzene is chemically stable and does not undergo biodegradation.

Environmental characteristics of vehicles are directly related to their operational characteristics, which are strongly influenced by the quality of motor fuels. By raising both the 90% boiling temperature and also the final boiling

point of the gasoline, an increase in the content of alkenes and aromatic hydrocarbons in fuels leads to an increase in the carbonization of engines. The strong influence of carbonization on operational (increased requirements for an octane number of gasoline), economic (increased fuel consumption) and environmental (increased emissions of CO and NO_x, polycyclic aromatic hydrocarbons, greenhouse gases) characteristics of vehicles compel car manufacturers to toughen the requirements for the boiling temperature of 90%, the final boiling point of the gasoline and the reduced content of aromatic hydrocarbons in fuel.

2.2 Perspective requirements to the quality of motor fuels in Russia

Catalytic reformat is the main high octane component of gasoline in Russia. As a result, on average, Russian gasoline contains up to 50% of aromatic hydrocarbons. Gasoline with a high octane rating produced by a number of oil plants, contains 90% of reformat and the aromatics content in gasoline reaches 60%. This situation is determined by the processing capacity of the gasoline production in the country. Table 2 presents the capacity of the production processes of the gasoline components regarding primary oil distillation compared with the data of other countries. Despite the approval of technical regulations specifying required standards for motor fuels [4], the actual quality of the gasoline remains much lower than that required. The aromatic content reaches 40–60% (with modern European standards $\leq 35\%$), sulphur content – up to 0.05% and the need for gasoline to have high detergent properties remains unsatisfied.

The shortage of high-octane gasoline remains a serious problem. At the same time the oil refining industry is unable to significantly increase the production of high-octane gasoline in its total output. The quality of domestic diesel fuels is below the required standard for cetane number (the actual cetane numbers are at 45-48, while the requirements of Euro-5 ≥ 51), the content of aromatic hydrocarbons (up to 35%, with modern European standards $\leq 15\%$), lubricating properties (scar diameter $\geq 500 \mu\text{m}$), sulphur content (up to 0.2% at the required $\leq 0.001\%$).

Table 2: The capacity of the gasoline production process regarding the capacity of the primary oil distillation, %.

Process	Russia	USA	Japan	Germany	China
Catalytic cracking	7-8	35	20	15	25
Reforming	14.2	24.1	15.5	17.1	25.6
Alkylation	0.20	6.55	0.91	1.20	0.58
Isomerization	0.3	3.8	4.4	3.1	-
Production of oxygenates	0.13	0.76	0.10	0.38	0.02

The results of the author's analysis of the influence of the quality of motor fuels on the operational and environmental characteristics of vehicles allows us to formulate requirements for the oil-refining industry which are necessary for attaining the highest possible improvement to the quality of fuels.

The first priority is to raise the average octane rating of gasoline in Russia. In addition, it is necessary to:

1. Reduce, as much as possible, the content of aromatic hydrocarbons in gasoline.
2. Minimize the benzene content in gasoline.
3. Reduce the final boiling point of gasoline to 150–160°C, which will reduce emissions of hydrocarbons and their oxy-derivatives.

Any reduction to either the content of aromatic hydrocarbons or the value of the final boiling point reduces the detergency properties of gasoline. The required improvement of detergency is not achieved through refining technology. Any reduction of the final boiling point of gasoline increases its saturated vapour pressure, leading to increased losses through fuel evaporation during storage, transportation, draining-filling and from the gasoline tanks of vehicles. Achieving a reduction in the saturated vapour pressure of gasoline by reducing the concentration of butanes is not advisable because it makes cold starting more difficult. Thus, it is necessary to attain the required reduction in the saturated vapour pressure of gasoline without compromising the mixture formation when starting a cold engine. This problem also cannot be solved through oil-refining technology.

Improvement to the quality of domestically produced diesel fuel requires:

1. A reduction in aromatic hydrocarbon content, firstly bi- or tricyclic, in diesel fuel. An elevated level of aromatic hydrocarbons affects environmental characteristics, increases carbonization and reduces the cetane number.
2. Increasing in cetane number from 45–48 to 51–55.
3. Lowering the sulphur content of the fuel to no more than 0.001%.
4. Increasing the part of fuel produced for use in low temperature conditions, in particular reducing the temperature limit of filterability.

Reducing the sulphur content in diesel fuel reduces its anti-wear properties (lubricity). Increased lubricity cannot be provided by oil-refining technology.

The required improvement to the quality of motor fuels produced by the refining industry is possible with significant modification to the structure of oil refining. It is necessary to develop the processes to improve fuel quality on a large capacity – isomerization, deep hydrotreating, catalytic cracking, alkylation, esterification of the catalytic cracking gasoline, hydrogenation and alkylation of the benzol containing gasoline fractions. Such a restructuring of the oil refining industry requires billions of dollars of capital expenditure for the foreseeable future, which, obviously, is not feasible. At the same time, the oil refining methods cannot provide the required level for some fuel properties, in particular the detergency of gasoline and the lubricating properties of diesel fuels, which can be improved only through the use of fuel additives.



3 Improving the quality of fuels in Russia by modernization of the oil refining industry

The amount of aromatic hydrocarbon content across all gasoline in Russia commonly reaches 50% or more. The present situation of a growing shortage in high-octane gasoline production in case of constantly expanding automobile fleet of the country poses a serious problem. The correspondence of the octane numbers with the fractions of reformat – the main high octane component of the domestic gasoline – is shown in fig. 2. It is seen from the data that the fractions of the reformat boiling in the range 62–100°C have very low octane numbers. Fractions of straight distillation of most oils with a boiling of 62–82°C also have octane numbers in the range of 59–61. As a result, the gasolines in Russia along with high-octane fractions boiling above 100°C contain low-octane fractions (62–64) with boiling at 62–100°C, which has an adverse effect on their operational properties [5].

Low octane numbers of the 62–100° reformat's fraction can be explained by the much lower degree of aromatization of C₆ hydrocarbons and the low mixing octane rating (80) for benzen.

This data reveals that it is inappropriate to subject an oil stock containing C₆ hydrocarbons to the process of reforming, thereby degrading the environmental properties of the gasoline due to an increase of benzene content. The reforming of C₆ hydrocarbons contained in the oil feedstock does not have a significant effect on the octane number of C₆ hydrocarbons in gasoline. Meanwhile, in Russia, a raw product for reforming the fraction with an initial boiling point (IBP) equal to 70°C is commonly used, which leads to a high content of benzene in the high-octane gasoline. The analysis shows that establishing the capacities of the isomerization of the balance amount of the fraction with IBP equal 82°C increases the octane number of the total gasoline output by 4–5 units. This can solve the task of reducing the proportion of low-octane gasoline in the total production and will decrease the content of aromatic hydrocarbons in gasoline by a factor of approximately 1.5 and a factor of 2–3 for benzene. Establishing the required capacities for isomerization (8.7 mln tons per year) requires investment of \$300–350 million. This is achievable and will ensure that Russian gasoline will be very close to the quality of EU gasoline.

An alternative way to increase high-octane gasoline production is through the creation of the complexes with large capacity: hydrorefining of vacuum gas-oil – catalytic cracking – alkylation, which requires massive capital investment and is unrealizable in the near future.

Because of the low capacity of catalytic cracking the diesel fuel produced in Russia is similar to the gas-oil from atmospheric oil distillation. Reducing the sulphur content to the standards of developed countries (0.001% by Euro-5) requires a significant increase in capacity and depth of hydrorefining, which in turn is unrealistic without huge capital investment. It should be noted that reducing the sulphur content in diesel fuel reduces its lubricity, which requires using the additives to improve lubricating properties. The cetane number can

also be increased by the use of special fuel additives. Some improvement to the environmental and operational properties of diesel fuels can be achieved through lowering the initial boiling point (IBP). Lowering the IBP of diesel fuel to 150–160°C decreases its pour point, significantly reducing the content of bicyclic aromatic hydrocarbons. Lowering the IBP of diesel fuel reduces the ratio C:H in it and leads to a decrease of carbon dioxide and soot emission per kWh. Such an improvement to fuel quality requires no expenditure.

It should be noted that of all the diesel fuel produced in Russia less than 1% is of arctic grade, approximately 10% is winter grade and the balance is the summer grade that does not correspond to the climate conditions of our country. Compulsory usage of summer diesel fuel in winter conditions results in excessive consumption. Reduction in the pour point of the total diesel fuel by 5° by reducing its IBP will undoubtedly lead to a significant reduction of diesel fuel consumption in winter.

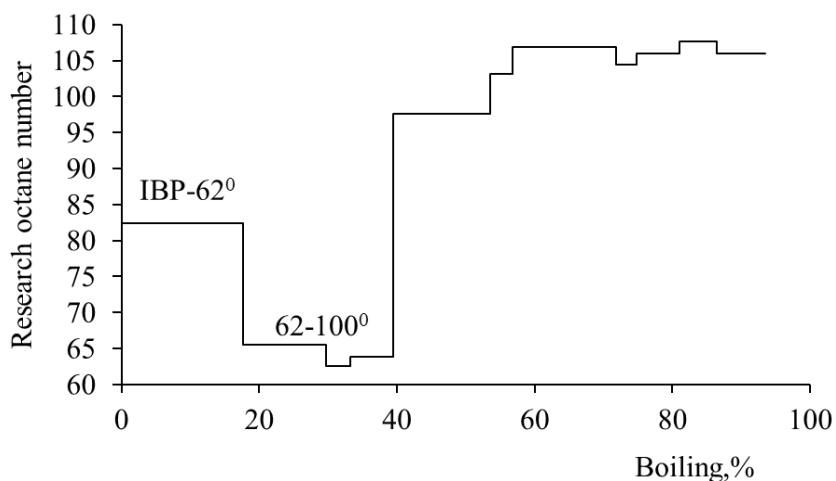

Figure 2: Distribution of research octane number value by the fractions of high severity reformat.

4 Motor fuel production by residueless oil refining

Increasing the motor fuel yield has always been and continues to be the strategic direction for the development of oil refining technology. The depletion of oil reserves and increased difficulties associated with crude oil production in the XXI century [6] will increasingly require the development of technologies of residueless oil refining into motor fuels with retention of their high operational and environmental properties [7]. In principle this is possible with the introduction of approximately 1.5% H₂, but it is extremely difficult due to the

difficulty of hydrogenation of goudron (required pressure is 20–30 MPa). Another possible way – the partial removal of carbon in the form of coke, is not effective enough as the resulting high-sulphur coke has no market. The problem can be solved by implementing an oil refining scheme, proposed here by the author (fig. 3), which produces a coke that is gasified and obtains H_2 , CH_3OH , sulphur and electricity.

The total output of environmentally friendly motor fuels produced by the scheme reaches 85%, which is significantly higher than the currently achieved output of light oil products (the best foreign plants – not more than 72–74%, with a depth of oil processing up to 92–98%, in Russia – about 50% with refining depths of 71–72%). The gasoline to diesel fuel ratio can be varied by changing the proportion of the vacuum gas-oil sent to catalytic cracking.

This gasoline, derived by the proposed scheme, has a higher research octane number (~ 91) and contains less than 0.6% benzene, $\leq 24\%$ aromatics and $\leq 7\%$ alkenes. The content of the most eco-friendly components (butane, isomerizate, alkylate) in it is 46.1%, which is higher than in the gasoline of modern quality.

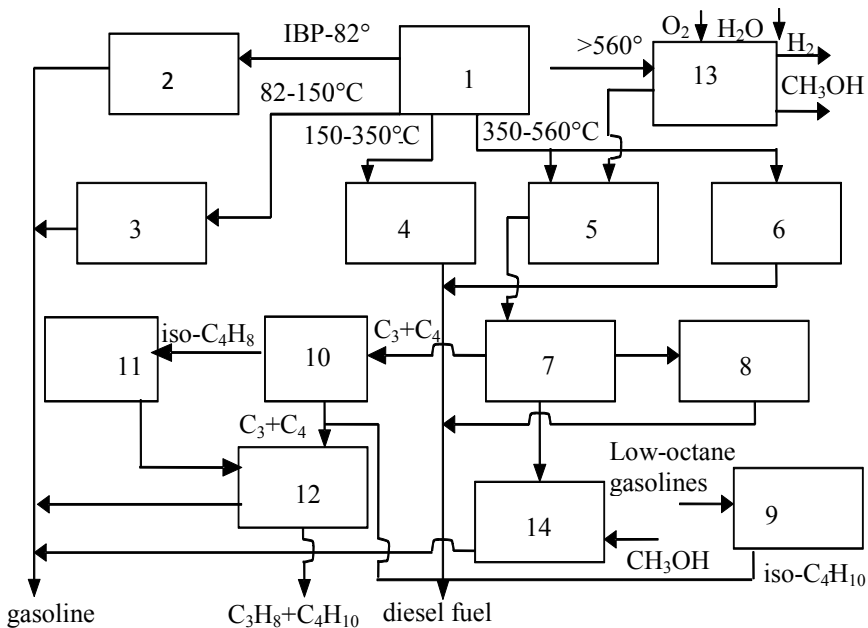

Figure 3: The scheme of the residueless oil refining: 1. preliminary distillation, 2. isomerization, 3. reforming, 4. hydrorefining, 5. hydrocracking, 6. hydrocracking, 7. catalytic cracking, 8. hydrogenation, 9. hydroisomerization, 10. isobutylene separation, 11. hydrogenation of isobutylene, 12. alkylation, 13. coking + gasification + methanol production, 14. esterification.

The combination of isomerization with the process of separating n-alkanes from catalysate and their isomerization (izosiv) increases the research octane number of total gasoline to 95.6.

Diesel fuel derived by the proposed scheme has the cetane number ~ 51 with contents $\leq 0.001\%$ of sulphur and $\leq 14\%$ of aromatic hydrocarbons. The presented scheme differs from existing refining schemes in modern plants in that it has a significantly lower capacity of reforming processes and catalytic cracking and has a complex of coking – gasification – production of methanol and hydrogen. This scheme requires significant capital investment so it can only be implemented in Russia in the long term, but for the present it is a guideline to the future development of the oil refining industry with the priorities being the development of isomerization and hydrotreating.

5 Improving the quality of motor fuels by the use of multifunctional additive

The most realistic, the quickest and the most cost effective way to improve the quality of fuel and so provide improved operational and environmental performance of vehicles, is the introduction of an efficient multi-functional fuel additive. A universal additive for motor fuels that can be used in both gasoline and diesel fuels would be highly desirable.

Based on the formulated requirements for a multi-functional additive to motor fuels and screening of the data on the catalytic properties of substances [8–10], we have proposed an additive with the composition of $[\text{RCOO}]_2 \text{Me}$ and developed the technology for its production. The additive is introduced into the fuel in ultra small amounts ranging from 9.25 ppm for gasoline to 27.75 ppm for diesel fuels. As the most powerful catalyst for gasification reactions, the additive eliminates carbon deposits almost completely. The engines' examination after a run with the additive shows the elimination of carbon deposits in the engine and on the spark plugs.

The additive also reduces emissions of polycyclic aromatic hydrocarbons by 95%. These substances are the precursors of carbon deposits, including the strongest carcinogen benzo(a)pyrene. Carbon deposit elimination mitigates the temperature regime in the engine because of improved heat removal, significantly reducing specific fuel consumption (fig. 4, table 3), emission of gaseous toxic substances (by 20–35%) and greenhouse gases.

Furthermore, the use of gasoline with the additive reduces the engine requirements for a specific gasoline octane number by up to 10 points and increases the cetane number of diesel fuels. Being a surfactant the additive improves the cleaning and anti-corrosion properties of fuels and also optimizes the fuel mixture. The lubricity and low temperature properties of diesel fuels are also improved. Atomic absorption analysis of the exhaust gases confirmed the absence of additional toxic components that had not been observed prior to the application of the additive.



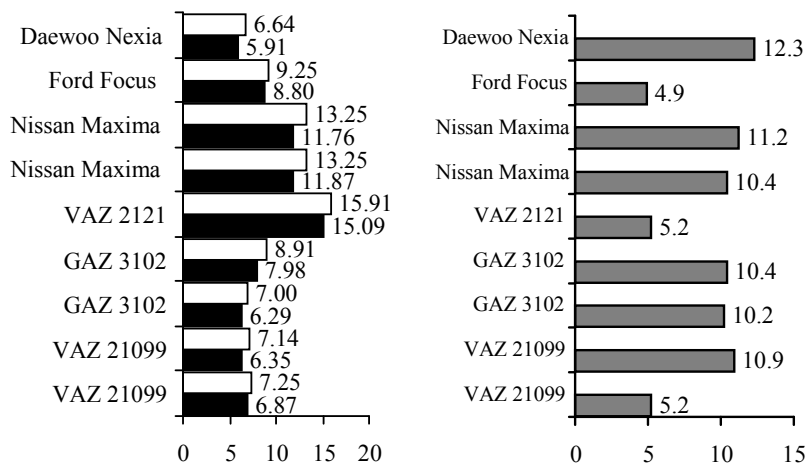

specific gasoline consumption, l/100 km specific consumption reduction, %

Figure 4: Influence of the additive on the specific consumption of gasoline
□ - without the additive; ■ - with the additive [11].

Table 3: Effect of the additive on the exhaust opacity of MAZ-54329
(the test bench of automobile company №1, Moscow).

Engine regime	Rotary speed, min ⁻¹	Power, kW	Opacity by Hartridge, %	Fuel consumption, kg/kW · h
Without additive before the test				
Full load	1500	142	68	0.316
Free acceleration	500→2100		45	
Maximum engine speed	2100		9	
With additive at the beginning of the test				
Full load	1500	143	53	0.310
Free acceleration	500→2100		37	
Maximum engine speed	2100		6	
With additive after about 700 km run in the regime of normal operation				
Full load	1500	149	54	0.296
Free acceleration	500→2100		35	
Maximum engine speed	2100		7	
The change in the regime of full load, %		+4.9	-21.6	-6.3

Thus, the complex catalytic and surface-active additive effect significantly improves fuel properties, and also provides energy efficiency and the environmentally friendly operation of vehicles with both gasoline and diesel engines.

6 Conclusion

This analysis has led to a formulation of the main goals for the improvement of the quality of motor fuels in Russia and has proposed the direction for their solution. The required changes within the refining industry have been substantiated. In the short term it is necessary to establish an isomerization capacity which is capable of providing the isomerization of the balance amount of the IBP-82° fraction of refining oil, increasing the initial boiling point of the raw product of reforming by up to 82°C and also lowering its final boiling point to 150–160°C which will improve the environmental properties of both gasoline and diesel fuel. The proposed scheme for highly efficient residueless oil refining will increase the yield of motor fuel, a highly significant factor when oil reserves are dwindling. The quickest way to achieve a significant increase in the energy efficiency of vehicles and an improvement to their operational and environmental performance is by using the highly efficient fuel additive developed by the author.

References

- [1] Magaril, E.R., *Influence of the Quality of Engine Fuels on the Operation and Environmental Characteristics of Vehicles: monograph*, [in Russian], KDU: Moscow, 2008.
- [2] Magaril, E. & Magaril, R., *Motor Fuels: the Problem of Energy Efficiency and Environmental Safety: monograph*, [in Russian], LAP LAMBERT Academic Publishing GmbH & Co: Saarbrücken, Germany, 2012.
- [3] Magaril, E., The influence of carbonization elimination on the environmental safety and efficiency of vehicle operation. *International Journal of Sustainable Development and Planning*, 8(2), pp. 231–245, 2013.
- [4] Technical regulations “On the Requirements for Automobile and Aviation Gasoline, Diesel and Marine Fuel, Jet Fuel and Furnace Fuel Oil” [in Russian], *Rossiyskaya Gazeta*, issue № 47 (4604), <http://www.rg.ru/2008/03/05/benzin.html>.
- [5] Gureev, A.A. & Azev, V.S., *Automobile Gasolines. Properties and Application* [in Russian], Neft i gaz: Moscow, pp.282–294., 1996.
- [6] BP Global Statistical Review of World Energy, 2012, www.bp.com.
- [7] Robinson, P.R., Petroleum processing overview (Chapter 1). *Practical Advances in Petroleum Processing*, eds. C.S. Hsu & P.R. Robinson, Practical advances in petroleum processing, Springer Science – Business Media, Inc.: New York, Vol. 1, pp. 1–78, 2006.



- [8] Roiter, V. A. (main editor), *Catalytic Properties of Substances*, [in Russian], Naukova dumka: Kiev, 1968.
- [9] Thomas, C., *Catalytic Processes and Proven Catalysts*, Academic Press: London and New York, 1970.
- [10] Germain, J. E., *Catalytic Conversion of Hydrocarbons*, Academic Press: London and New York, 1969.
- [11] Magaril, E., Improving car environmental and operational characteristics using a multifunctional fuel additive. *WIT Transactions on Ecology and the Environment*, 147, WIT Press: UK, pp. 373–384, 2011.

